

# grace

**Grace Motion Spot light  
Installation Manual**

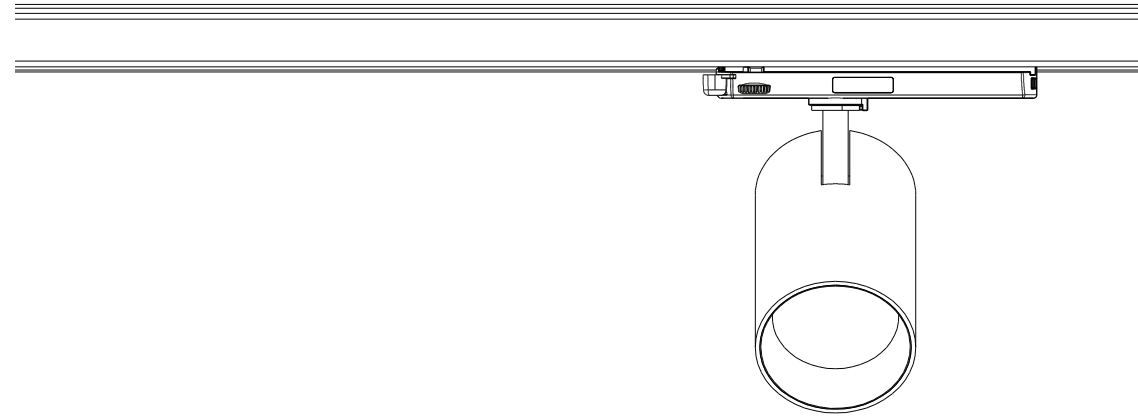

## Important Safety Instructions:

To ensure correct function and safety, please read and follow all instructions carefully before using the product:

1. Turn off power supply before installation or before doing any maintenance work.
  2. Do not install any luminaire near the heat source.
  3. Do not exceed the nominal supply voltage or amperage ratings.
  4. All wiring and installation of the light fitting must adhere to local and national wiring rules.
  5. Take care not to pull any electrical wires during unpacking as this may damage the connection.
  6. Lay out all the components on a smooth surface and make sure there are no components missing before assembling.
  7. To avoid injury or damage to the fitting, please ensure that power leads and screws are secure before connecting the power.
  8. Please keep instructions for future reference.
  9. Please refer to IP(Ingress Protection) rating of this luminaire when deciding the location of installation.
  10. Do not attempt to energize anything other than lighting track luminaires on the track.
- To reduce the risk of fire and electric shock, do not attempt to connect power tools, extension cords, appliances, and the like to the track.
11. Do not connect a track to more than one branch circuit unless the track is constructed so that it can be used with more than one branch circuit. Check with a qualified electrician. Although the track lighting system may seem to operate.
  12. Test the compatibility of the track system and track lamp adapter before installing the track lamp

## Regulations

To ensure correct functionality and safety please read instructions carefully before using this product. This luminaire complies with AS/NZS 60598.2.1.

All wiring and installation of this luminaire must adhere to local and national wiring rules eg AS/NZS 3000:2007 Amendment 2:2012 Electrical Installation

## Track installation

DALI track layout

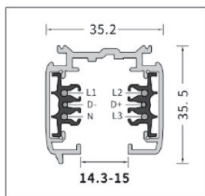

dimensions and layout(unit:mm)

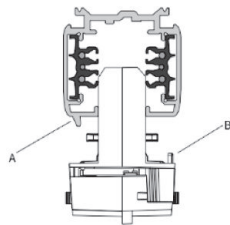

- Insert the adapter into the track, noting the position of the mechanical keys (A) and (B).

## Installation Procedure

### WARNING

1. Switch off before installation.
2. Switch on only after complete installation and examination of the circuit.
3. Professional electrician for installation and maintenance only.



## Installation

